

VALVE FITTINGS WELLHEAD COMPONENTS

HIGH PRESSURE WELLHEAD COMPONENTS

- VENTED CAP BODY GREASE FITTINGS
- HIGH PRESSURE FITTINGS
- PACKING / BONNET INJECTION FITTINGS
- BUTTON HEAD FITTINGS
- BODY VENT (BLEEDER) FITTINGS
- INTERNAL CHECK FITTINGS
- CAVITY PLUGS
- GREASE FITTINGS



VENTED CAP BODY GREASE FITTINGS

Features

- Maximum working pressure: 10,000 PSIG (690 Bar).
- Special design to enable the lubricant and sealant to flow through the Ball support and the operating of spring smoothly.
- Special curling design to secure the spring and internal parts from dropping out.
- All metal construction, application in both high temperature and low temperature environments

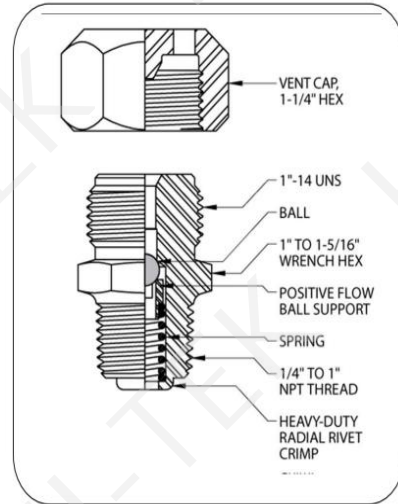

Standard Structure :

Positive Flow Ball Support

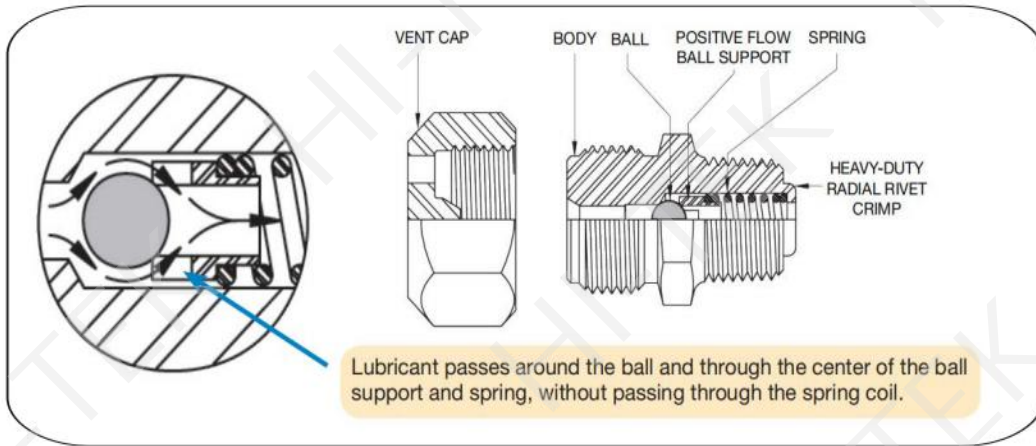

Free Flow Design

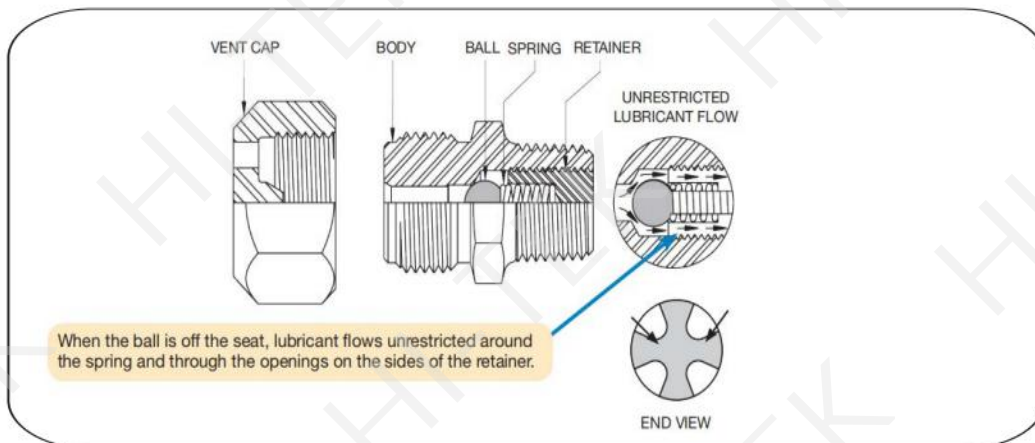

Vented Cap Body Grease Fittings with Giant Button

Drawing	Part No.	Thread Size	Material	Plating	Ball	Spring
	GB-1-1215	1-11.5NPT	1215	Zinc	CA	316 SS
	GB-1-4140		4140	Zinc	440C	316 SS
	GB-1-SS		316 SS	/	K-Monel	Inconel X-750
	GB-3/4-1215	3/4-14NPT	1215	Zinc	CA	316 SS
	GB-3/4-4140		4140	Zinc	440C	316 SS
	GB-3/4-SS		316 SS	/	K-Monel	Inconel X-750
	GB-1/2-1215	1/2-14NPT	1215	Zinc	CA	316 SS
	GB-1/2-4140		4140	Zinc	440C	316 SS
	GB-1/2-SS		316 SS	/	K-Monel	Inconel X-750
	GB-3/8-1215	3/8-18NPT	1215	Zinc	CA	316 SS
	GB-3/8-4140		4140	Zinc	440C	316 SS
	GB-3/8-SS		316 SS	/	K-Monel	Inconel X-750
	GB-1/4-1215	1/4-18NPT	1215	Zinc	CA	316 SS
	For Service to 10,000 PSI GB-1/4-4140		4140	Zinc	440C	316 SS
	GB-1/4-SS		316 SS	/	K-Monel	Inconel X-750

Positive Flow, Vented Cap Body Grease Fittings without Giant Button

Drawing	Part No.	Thread Size	Material	Plating	Ball	Spring
	WB-1-1215	1-11.5NPT	1215	Zinc	CA	316 SS
	WB-1-4140		4140	Zinc	440C	316 SS
	WB-1-SS		316 SS	/	K-Monel	Inconel X-750
	WB-3/4-1215	3/4-14NPT	1215	Zinc	CA	316 SS
	WB-3/4-4140		4140	Zinc	440C	316 SS
	WB-3/4-SS		316 SS	/	K-Monel	Inconel X-750
	WB-1/2-1215	1/2-14NPT	1215	Zinc	CA	316 SS
	WB-1/2-4140		4140	Zinc	440C	316 SS
	WB-1/2-SS		316 SS	/	K-Monel	Inconel X-750
	WB-3/8-1215	3/8-18NPT	1215	Zinc	CA	316 SS
	WB-3/8-4140		4140	Zinc	440C	316 SS
	WB-3/8-SS		316 SS	/	K-Monel	Inconel X-750
	WB-1/4-1215	1/4-18NPT	1215	Zinc	CA	316 SS
	For Service to 10,000 PSI WB-1/4-4140		4140	Zinc	440C	316 SS
	WB-1/4-SS		316 SS	/	K-Monel	Inconel X-750

Free Flow Vented Cap Body Grease Fittings with Giant Button Head 6D

Drawing	Part No.	Thread Size	Material	Plating	Ball	Spring
	GB-FF-1-1215	1-11.5NPT	1215	Zinc	CA	316 SS
	GB-FF-1-4140		4140	Zinc	440C	316 SS
	GB-FF-1-SS		316 SS	/	K-Monel	Inconel X-750
	GB-FF-3/4-1215	3/4-14NPT	1215	Zinc	CA	316 SS
	GB-FF-4140		4140	Zinc	440C	316 SS
	GB-FF-3/4-SS		316 SS	/	K-Monel	Inconel X-750
	GB-FF-1/2-1215	1/2-14NPT	1215	Zinc	CA	316 SS
	GB-FF-1/2-4140		4140	Zinc	440C	316 SS
	GB-FF-1/2-SS		316 SS	/	K-Monel	Inconel X-750
	GB-FF-3/8-1215	3/8-18NPT	1215	Zinc	CA	316 SS
	GB-FF-3/8-4140		4140	Zinc	440C	316 SS
	GB-FF-3/8-SS		316 SS	/	K-Monel	Inconel X-750
	GB-FF-1/4-1215	1/4-18NPT	1215	Zinc	CA	316 SS
	GB-FF-1/4-4140		4140	Zinc	440C	316 SS
GB-FF-1/4-SS	316 SS		/	K-Monel	Inconel X-750	
For Service to 10,000 PSI	GB-FF-1/4-SS		316 SS	/	K-Monel	Inconel X-750

High Pressure Lubrication and Sealant Fittings Lubrication (Sealant) Fitting 9/16" Autoclave Style

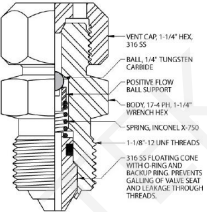
Drawing	Part No.	Thread Size	Material	Plating	Ball	Spring
	WBA-9/16-SS	1-1/8"-12 UNF	316 SS	/	Tungsten Carbide	Inconel X-750
For Service to 20,000 PSI						

Leak locker fitting Giant button head For temporary sealing of leaking button head fittings

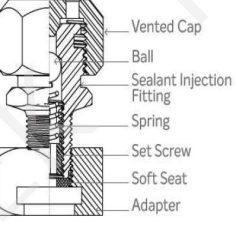
Drawing	Part No.	Thread Size	Material	Plating	Ball	Spring
	GBL-5/8-SS	5/8 " UNF	316 SS	/	Tungsten Carbide	Inconel X-750
For Service to 20,000 PSI						

FREE FLOW PACKING INJECTION FITTINGS

FEATURES

Maximum working pressure: 10,000 PSIG (690 Bar).

Special design to enable the lubricant and sealant to flow through the Ball support and the operating of spring smoothly.

Special curling design to secure the spring and internal parts from dropping out.

All metal construction, application in both high temperature and low temperature environments.

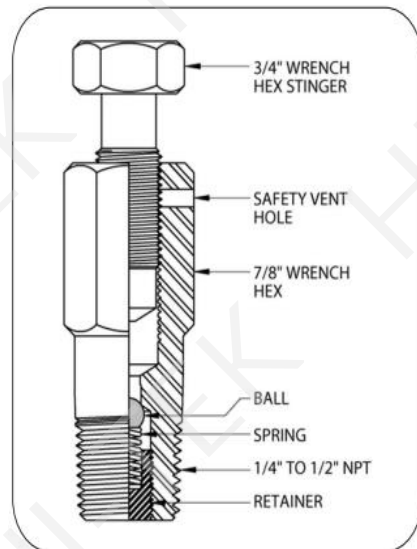

Free Flow Design

When the ball is off the seat, lubricant flows unrestricted around the spring and through the openings on the sides of the retainer.

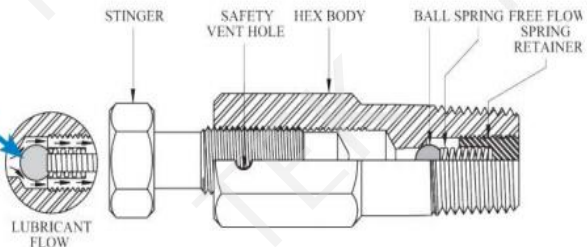

PACKING / BONNET INJECTION FITTINGS

FEATURES

- Maximum working pressure: 10,000 PSIG (690 Bar).
- All metal construction, application in both high temperature and low temperature environments.

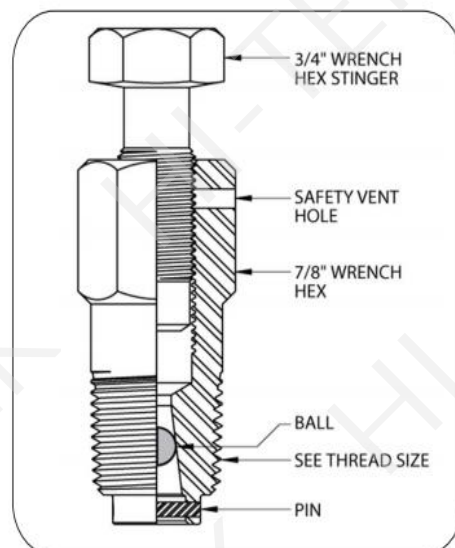

Free Flow Packing Injection Fitting

Drawing	Part No.	Thread Size	Material	Plating	Ball	Spring
	PF-FF-1/2-1215	1/2-14NPT	1215	Zinc	CA	316 SS
	PF-FF-1/2-4140		4140	Zinc	440C	316 SS
	PF-FF-1/2-SS		316 SS	/	K-Monel	Inconel X-750
	PF-FF-3/8-1215	3/8-18NPT	1215	Zinc	CA	316 SS
	PF-FF-3/8-4140		4140	Zinc	440C	316 SS
	PF-FF-3/8-SS		316 SS	/	K-Monel	Inconel X-750
	PF-FF-1/4-1215	1/4-18NPT	1215	Zinc	CA	316 SS
	PF-FF-1/4-4140		4140	Zinc	440C	316 SS
PF-FF-1/4-SS	316 SS		/	K-Monel	Inconel X-750	
For Service to 10,000 PSI	PF-FF-1/4-SS		316 SS	/	K-Monel	Inconel X-750

Packing Injection Fittings (Floating Ball-Taper Cavity)

Drawing	Part No.	Thread Size	Material	Plating	Ball	Spring
	PF-1/2-1215	1/2-14NPT	1215	ZINC	CA	316 SS
	PF-1/2-4140		4140	ZINC	440C	316 SS
	PF-1/2-SS		316 SS	/	K-Monel	Inconel X-750
	PF-3/8-1215	3/8-18NPT	1215	ZINC	CA	316 SS
	PF-3/8-4140		4140	ZINC	440C	316 SS
	PF-3/8-SS		316 SS	/	K-Monel	Inconel X-750
	PF-1/4-1215	1/4-18NPT	1215	ZINC	CA	316 SS
	PF-1/4-4140		4140	ZINC	440C	316 SS
PF-1/4-SS	316 SS		/	K-Monel	Inconel X-750	
For Service to 10,000 PSI	PF-1/4-SS		316 SS	/	K-Monel	Inconel X-750

Combination Lube Adapter

Grease gun lube adapter with giant button head and ball check

Drawing	Part No.	Thread Size	Material	Plating	Ball	Spring
	CLA-1/2-1215	1" UNF	1215	Zinc	CA	316 SS
	CLA-1/2-4140		4140	Zinc	440C	316 SS
	CLA-1/2-SS		316 SS	/	K-Monel	Inconel X-750
	CLA-3/8-1215	7/8" UNF	1215	Zinc	CA	316 SS
	CLA-3/8-4140		4140	Zinc	440C	316 SS
	CLA-3/8-SS		316 SS	/	K-Monel	Inconel X-750
	CLA-1/4-1215	3/4" UNF	1215	Zinc	CA	316 SS
	CLA-1/4-4140		4140	Zinc	440C	316 SS
CLA-1/4-SS	316 SS		/	K-Monel	Inconel X-750	
For Service to 10,000 PSI	CLA-1/4-SS		316 SS	/	K-Monel	Inconel X-750

Gaint button head fitting --Double ball

Drawing	Part No.	Thread Size	Material	Plating	Ball	Spring
	GBD-1-1215	1-11.5NPT	1215	Zinc	CA	316 SS
	GBD-1-4140		4140	Zinc	440C	316 SS
	GBD-1-SS		316 SS	/	K-Monel	Inconel X-750
	GBD-3/4-1215	3/4-14NPT	1215	Zinc	CA	316 SS
	GBD-3/4-4140		4140	Zinc	440C	316 SS
	GBD-3/4-SS		316 SS	/	K-Monel	Inconel X-750
	GBD-1/2-1215	1/2-14NPT	1215	Zinc	CA	316 SS
	GBD-1/2-4140		4140	Zinc	440C	316 SS
	GBD-1/2-SS		316 SS	/	K-Monel	Inconel X-750
	GBD-3/8-1215	3/8-18NPT	1215	Zinc	CA	316 SS
	GBD-3/8-4140		4140	Zinc	440C	316 SS
	GBD-3/8-SS		316 SS	/	K-Monel	Inconel X-750
	GBD-1/4-1215	1/4-18NPT	1215	Zinc	CA	316 SS
	GBD-1/4-4140		4140	Zinc	440C	316 SS
	For Service to 10,000 PSI GBD-1/4-SS		316 SS	/	K-Monel	Inconel X-750

Gaint button head fitting --Single ball

Drawing	Part No.	Thread Size	Material	Plating	Ball	Spring
	GBS-1-1215	1-11.5NPT	1215	Zinc	CA	316 SS
	GBS-1-4140		4140	Zinc	440C	316 SS
	GBS-1-SS		316 SS	/	K-Monel	Inconel X-750
	GBS-3/4-1215	3/4-14NPT	1215	Zinc	CA	316 SS
	GBS-3/4-4140		4140	Zinc	440C	316 SS
	GBS-3/4-SS		316 SS	/	K-Monel	Inconel X-750
	GBS-1/2-1215	1/2-14NPT	1215	Zinc	CA	316 SS
	GBS-1/2-4140		4140	Zinc	440C	316 SS
	GBS-1/2-SS		316 SS	/	K-Monel	Inconel X-750
	GBS-3/8-1215	3/8-18NPT	1215	Zinc	CA	316 SS
	GBS-3/8-4140		4140	Zinc	440C	316 SS
	GBS-3/8-SS		316 SS	/	K-Monel	Inconel X-750
	GBS-1/4-1215	1/4-18NPT	1215	Zinc	CA	316 SS
	GBS-1/4-4140		4140	Zinc	440C	316 SS
	For Service to 10,000 PSI GBS-1/4-SS		316 SS	/	K-Monel	Inconel X-750

Lock Seal Fitting – Double Ball Check

Drawing	Part No.	Thread Size	Material	Plating	Ball	Spring
	LSD-3/4-1215	3/4-14NPT	1215	Zinc	CA	316 SS
	LSD-3/4-4140		4140	Zinc	440C	316 SS
	LSD-3/4-SS		316 SS	/	K-Monel	Inconel X-750
	LSD-1/2-1215	1/2-14NPT	1215	Zinc	CA	316 SS
	LSD-1/2-4140		4140	Zinc	440C	316 SS
	LSD-1/2-SS		316 SS	/	K-Monel	Inconel X-750
	LSD-3/8-1215	3/8-18NPT	1215	Zinc	CA	316 SS
	LSD-3/8-4140		4140	Zinc	440C	316 SS
	LSD-3/8-SS		316 SS	/	K-Monel	Inconel X-750
	LSD-1/4-1215	1/4-18NPT	1215	Zinc	CA	316 SS
	LSD-1/4-4140		4140	Zinc	440C	316 SS
For Service to 10,000 PSI LSD-1/4-SS	316 SS		/	K-Monel	Inconel X-750	

BODY VENT (BLEEDER) FITTINGS

Drawing	Part No.	Thread Size	Material	Hex Size	Plating	Ball
	BVF-1-1/2-1215	1-1/2 NPT	1215	2-5/8 "	ZINC	440C
	BVF-1-1/2-4140		4140		ZINC	TC
	BVF-1-1/2-SS		316 SS		/	
	BVF-1-1/4-1215	1-1/4 NPT	1215	1-3/4 "	ZINC	440C
	BVF-1-1/4-4140		4140		ZINC	TC
	BVF-1-1/4-SS		316 SS		/	
	BVF-1-1215	1-11.5NPT	1215	1-5/16 "	ZINC	440C
	BVF-1-4140		4140		ZINC	TC
	BVF-1-SS		316 SS		/	
	BVF-3/4-1215	3/4-14NPT	1215	1-1/8 "	ZINC	440C
	BVF-3/4-4140		4140		ZINC	TC
	BVF-3/4-SS		316 SS		/	
	BVF-1/2-1215	1/2-14NPT	1215	7/8 "	ZINC	440C
	BVF-1/2-4140		4140		ZINC	TC
	BVF-1/2-SS		316 SS		/	
	BVF-3/8-1215	3/8-18NPT	1215	7/8 "	ZINC	440C
	BVF-3/8-4140		4140		ZINC	TC
	BVF-3/8-SS		316 SS		/	
	BVF-1/4-1215	1/4-18NPT	A105	7/8 "	ZINC	440C
	BVF-1/4-4140		304SS		ZINC	TC
For Service to 10,000 PSI BVF-1/4-SS	316 SS		/			

Hex Socket Head Style

Drawing	Part No.	Thread Size	Material	Hex Size	Plating	Ball
	HSH-3/4-1215	3/4-14NPT	1215	1-1/8 "	ZINC	440C
	HSH-3/4-4140		4140		ZINC	TC
	HSH-3/4-SS		316 SS		/	
	HSH-1/2-1215	1/2-14NPT	1215	7/8 "	ZINC	440C
	HSH-1/2-4140		4140		ZINC	TC
	HSH-1/2-SS		316 SS		/	
	HSH-3/8-1215	3/8-18NPT	1215	7/8 "	ZINC	440C
	HSH-3/8-4140		4140		ZINC	TC
	HSH-3/8-SS		316 SS		/	
	HSH-1/4-1215	1/4-18NPT	1215	7/8 "	ZINC	440C
	HSH-1/4-4140		4140		ZINC	TC
	HSH-1/4-SS		316 SS		/	
For Service to 10,000 PSI	HSH-1/4-SS		316 SS		/	

INTERNAL CHECK FITTINGS, Single Ball, Soft Seat, Spring Based

Drawing	Part No.	Thread Size	Material	Plating	Ball	Spring
	ICF-1/2-4140	1/2-14NPT	4140	Zinc	K-Monel	Inconel X-750
	ICF-1/2-SS		316 SS	Zinc	K-Monel	Inconel X-750
	ICF-3/8-4140	3/8-18NPT	4140	/	K-Monel	Inconel X-750
	ICF-3/8-SS		316 SS	Zinc	K-Monel	Inconel X-750
	ICF-1/4-4140	1/4-18NPT	4140	Zinc	K-Monel	Inconel X-750
	For Service to 10,000 PSI		ICF-1/4-SS	316 SS	/	K-Monel

Cavity Plugs

Drawing	Part No.	Thread Size	Material	Plating
	CP-1-1215	1-11.5NPT	1215	Zinc
	CP-1-4140		4140	Zinc
	CP-1-SS		316 SS	/
	CP-3/4-1215	3/4-14NPT	1215	Zinc
	CP-3/4-4140		4140	Zinc
	CP-3/4-SS		316 SS	/
	CP-1/2-1215	1/2-14NPT	1215	Zinc
	CP-1/2-4140		4140	Zinc
	CP-1/2-SS		316 SS	/

Grease Fitting

Angle: Staight, 30°,45°,90°

Thread size: #10,#6,1/8" TO 1/2",M5 TO M16

Material: Brass, Carbon steel, SS 304

